

# CONEXÕES AUTOMÁTICAS PARA USO ALIMENTAR SÉRIE F

Os materiais constituintes dessas conexões são adequados para empregar mesmo na indústria alimentar. De fato as partes em latão são tratadas com níquel químico ao fosforo, segundo o standard NSF®/ANSI 51 do programa alimentar; as vedações são em FKM/FPM aprovadas pela FDA. A conexão não contém partes em tecnopolímero e conseqüentemente são evitados problemas de compatibilidade com detergentes e outros agentes químicos. Esta escolha de materiais permite o uso da conexão até 150°C e isso é muito interessante mesmo em aplicações diferentes do setor alimentar, com temperatura elevada.

As rosças são cilíndricas com vedação pneumática com O-Ring; esta solução evita o emprego de selantes do tipo (Teflon® ou outro), que na fase de rosqueamento ou desrosqueamento poderão deixar fragmentos sólidos que contaminam o ambiente ou o fluido; estas conexões podem ser rosqueadas quantas vezes quiser garantindo sempre vedação pneumática e limpeza, a escolha dos materiais e dos tratamentos faz essas conexões interessantes mesmo para aplicações nos setores da química, farmacêutica, médica, eletrônica, etc.

É disponível uma gama de conexões standard mas, sob consulta, é possível realizar outros tipos.



DADOS TÉCNICOS		
Conexão rosçada		M5 - G1/8" - G1/4" - G3/8" - G1/2"
Diâmetro	mm	Ø 4 - Ø 6 - Ø 8 - Ø 10
Faixa de temperatura	°C	-20 ÷ +150
	°F	-4 ÷ 302
Faixa de pressão		-0,99 bar ÷ 16 bar / -0,099 MPa ÷ 1,6 MPa
Tubo aconselhado		RilsanPA 11 - Nylon 6 - Poliamida 12 - Polipropileno

## COMPONENTES

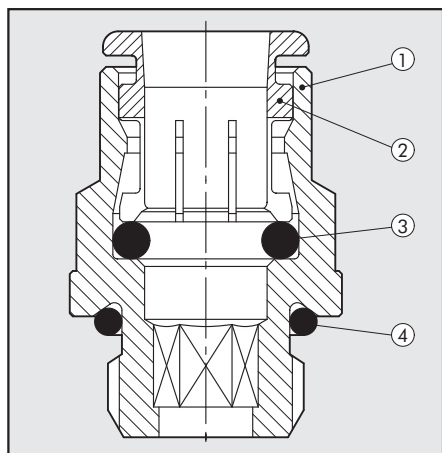

- ① Corpo: latão com níquel químico fosforoso segundo norma standard NSF®/ANSI 51
- ② Pinça: latão com níquel químico fosforoso segundo norma standard NSF®/ANSI 51
- ③ Vedação do tubo: FKM/FPM
- ④ Vedação da rosca: FKM/FPM

## VANTAGENS

### O Ring sob a rosca

Rosquear e desrosquear qto quiser; nenhum fragmento de Teflon® ou cola que possa contaminar o fluido

### Resistência à corrosão

Níquel químico fosforoso + FKM/FPM são compatíveis com muitíssimas substâncias

### Nenhuma parte em plástico

Nenhum risco de incompatibilidade

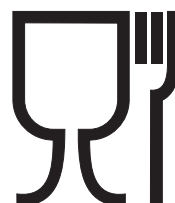



### RETA CILINDRICA MACHO R1 NSF

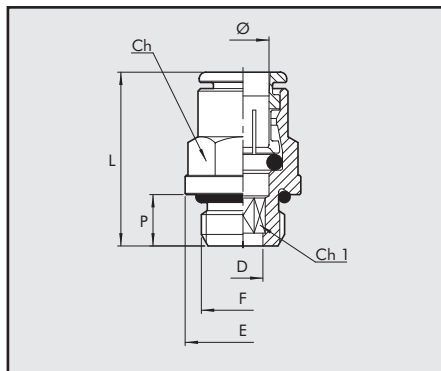

Cod.	Ref.	Ø	F	Ch	Ch1	P	L	D	E
2F01001	R1 NSF	4	M5	Ø9.9	2.5	4	21.5	2.6	9.9
2F01002	R1 NSF	4	1/8	11	3	6	20.5	3.1	15
2F01003	R1 NSF	4	1/4	12	3	8	22.5	3.1	18
2F01000	R1 NSF	6	M5	Ø12.9	2.5	4	25	2.6	12.9
2F01007	R1 NSF	6	1/8	13	4	6	27.5	4.2	15
2F01008	R1 NSF	6	1/4	13	4	8	26.5	4.2	18
2F01009	R1 NSF	8	1/8	14	5	6	28.5	5.2	15.6
2F01010	R1 NSF	8	1/4	15	6	8	27	6.2	18
2F01011	R1 NSF	8	3/8	15	6	9	28	6.2	21
2F01012	R1 NSF	10	1/4	17	7	8	33.5	7.2	20
2F01013	R1 NSF	10	3/8	17	8	9	30.5	8.2	21
2F01022	R1 NSF	10	1/2	17	10	11	31.5	10.2	26

### RETA CONICA MACHO RL1C NSF

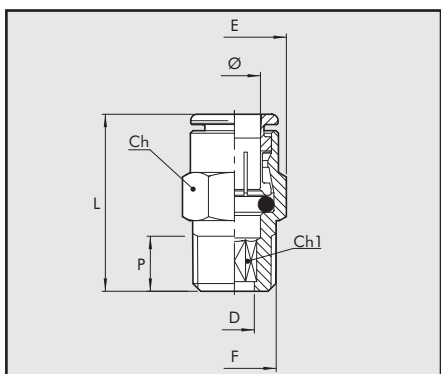

Cod.	Ref.	Ø	F	Ch	Ch1	P	L	D	E
2F01C02	R1C NSF	4	1/8	10	2.5	6.2	20.5	3.1	11.5
2F01C07	R1C NSF	6	1/8	12	4	6.2	24	4.2	13.8
2F01C08	R1C NSF	6	1/4	14	4	8.5	25.5	4.2	16
2F01C09	R1C NSF	8	1/8	14	5	6.2	27.5	5.2	16
2F01C10	R1C NSF	8	1/4	14	6	8.5	27.5	6.2	16
2F01C11	R1C NSF	8	3/8	17	6	9	27	6.2	19.6
2F01C13	R1C NSF	10	1/4	17	7	8.5	34.5	7.2	19.6
2F01C14	R1C NSF	10	3/8	17	7	9	30.5	7.2	19.6

### RETA FEMEA R2 NSF

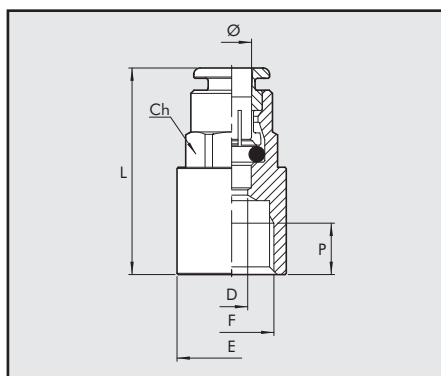

Cod.	Ref.	Ø	F	Ch	P	L	D	E
2F02001	R2 NSF	4	1/8	10	7	27	3	14
2F02005	R2 NSF	6	1/8	13	7	30	5	15
2F02006	R2 NSF	6	1/4	13	8	32	5	17
2F02007	R2 NSF	8	1/8	14	7	30	7	17
2F02008	R2 NSF	8	1/4	14	8	32	7	17
2F02011	R2 NSF	10	1/4	17	8	35	9	20

### RETA INTERMEDIÁRIA R3 NSF

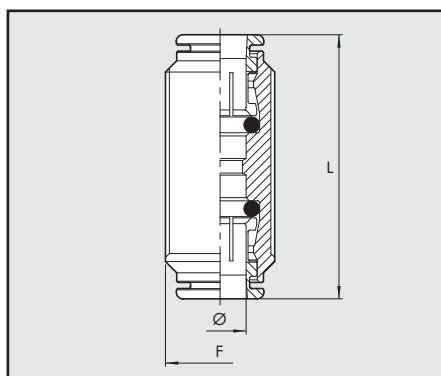

Cod.	Ref.	Ø	F	L
2F03001	R3 NSF	4	M13X1	33
2F03003	R3 NSF	6	M15X1	40
2F03004	R3 NSF	8	M17X1	41
2F03005	R3 NSF	10	M20X1	47

### L- INTERMEDIÁRIO R4 NSF

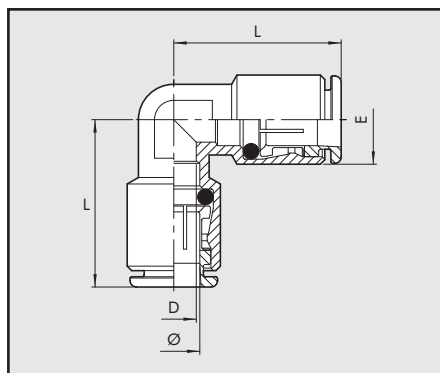

Cod.	Ref.	Ø	D	E	L
2F04001	R4 NSF	4	2.5	9.5	18
2F04003	R4 NSF	6	4.5	13.5	22
2F04004	R4 NSF	8	7	14	26
2F04005	R4 NSF	10	9	17	30

### T- INTERMEDIÁRIO R5 NSF

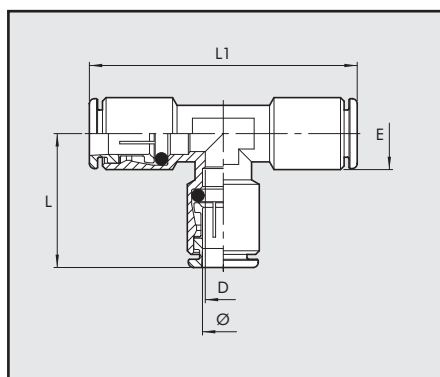

Cod.	Ref.	Ø	L	L1	D	E
2F05001	R5 NSF	4	21	42	3.5	9.5
2F05003	R5 NSF	6	24	48	5	12.5
2F05004	R5 NSF	8	26	52	7	14
2F05005	R5 NSF	10	30	60	9	17

### ADAPTADOR ROSCA-TUBO R6 NSF

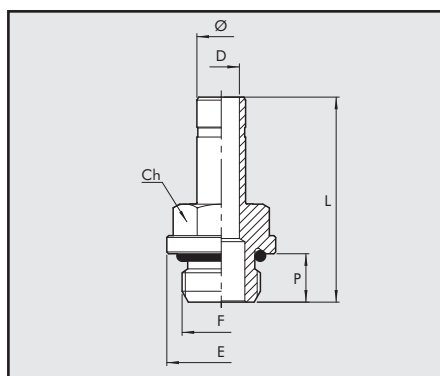

Cod.	Ref.	Ø	F	Ch	P	L	D	E
2F06001	R6 NSF	4	M5	8	4	25.2	2.5	9
2F06002	R6 NSF	4	1/8	13	6	28.9	2.5	15
2F06003	R6 NSF	4	1/4	14	8	32.4	2.2	18
2F06000	R6 NSF	6	M5	9	4	25.7	2.7	10
2F06007	R6 NSF	6	1/8	13	6	29.4	4	15
2F06008	R6 NSF	6	1/4	14	8	32.9	4	18
2F06009	R6 NSF	8	1/8	13	6	30.6	5.5	15
2F06010	R6 NSF	8	1/4	14	8	34	6	18
2F06011	R6 NSF	8	3/8	17	9	35.4	6	22
2F06012	R6 NSF	10	1/4	14	8	35.6	7.8	18
2F06013	R6 NSF	10	3/8	17	9	37.1	8	22

### RETA INTERMEDIÁRIA PASSAMURO R10 NSF

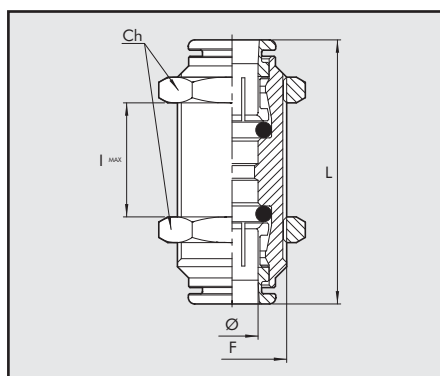

Cod.	Ref.	Ø	F	Ch	L	lmax
2F11001	R10 NSF	4	M13x1	16	33	11
2F11003	R10 NSF	6	M15x1	17	40	16
2F11004	R10 NSF	8	M17x1	20	41	19
2F11005	R10 NSF	10	M20x1	24	47	21



### L- MACHO CILINDRICO GIRATORIO R31 NSF

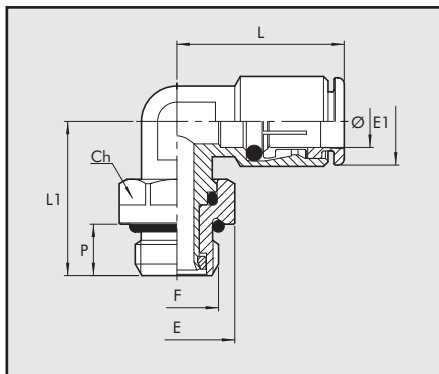

Cod.	Ref.	∅	F	Ch	E	E1	L	L1	P
2F31001	R31 NSF	4	M5	9	9	10	21	19	4
2F31002	R31 NSF	4	1/8	13	15	10	21	21	6
2F31003	R31 NSF	4	1/4	16	18	10	21	25	8
2F31007	R31 NSF	6	M5	9	8	11.8	24	17.5	4
2F31008	R31 NSF	6	1/8	13	15	12.5	24	21	6
2F31009	R31 NSF	6	1/4	16	18	12.5	25.5	25	8
2F31010	R31 NSF	8	1/8	13	15	14	26	22.5	6
2F31011	R31 NSF	8	1/4	16	18	14	26	25	8
2F31012	R31 NSF	8	3/8	19	22	14	27.5	30.5	9
2F31013	R31 NSF	10	1/4	16	18	16.5	30	27	8
2F31014	R31 NSF	10	3/8	19	22	16.5	30	30.5	9
2F31015	R31 NSF	10	1/2	22	26	16.5	31	32	11

### L- MACHO CONICO GIRATORIO R31C NSF

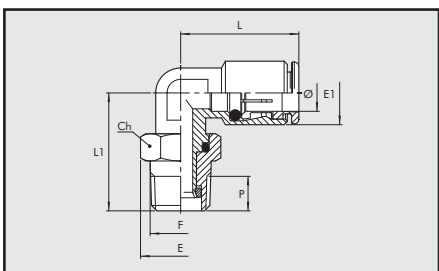

Cod.	Ref.	∅	F	Ch	E	E1	L	L1	P
2F31C02	R31C NSF	4	1/8	12	13.3	10	21	22	6.2
2F31C03	R31C NSF	4	1/4	16	17.7	10	21	27	8.5
2F31C08	R31C NSF	6	1/8	12	13.3	11.8	24	22	6.2
2F31C09	R31C NSF	6	1/4	16	17.7	12.5	25.5	27	8.5
2F31C10	R31C NSF	8	1/8	12	13.3	14	26	23.5	6.2
2F31C11	R31C NSF	8	1/4	16	17.7	14	26	27	8.5
2F31C12	R31C NSF	8	3/8	19	22	14	27.5	31	9
2F31C13	R31C NSF	10	1/4	16	17.7	16.5	30	29	8.5
2F31C14	R31C NSF	10	3/8	19	22	16.5	30	31	9

### T- CENTRAL MACHO CILINDRICO GIRATORIO R32 NSF

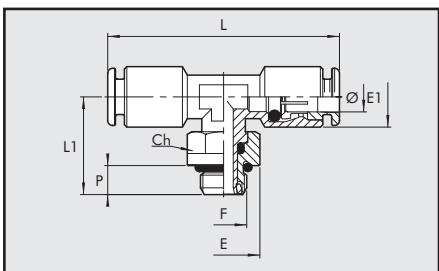

Cod.	Ref.	∅	F	Ch	E	E1	L	L1	P
2F32002	R32 NSF	4	1/8	13	15	10	41.5	21	6
2F32008	R32 NSF	6	1/8	13	15	12.5	47.5	21	6
2F32009	R32 NSF	6	1/4	16	18	12.5	50.5	25	8
2F32010	R32 NSF	8	1/8	13	15	14	52	22.5	6
2F32011	R32 NSF	8	1/4	16	18	14	52	25	8
2F32012	R32 NSF	8	3/8	19	22	14	56	30.5	9
2F32013	R32 NSF	10	1/4	16	18	16.5	60.5	27	8
2F32014	R32 NSF	10	3/8	19	22	16.5	60.5	30.5	9

### T- LATERAL MACHO CILINDRICO GIRATORIO R38 NSF

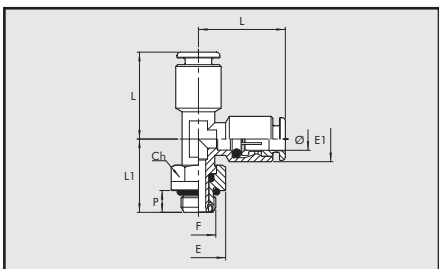

Cod.	Ref.	∅	F	Ch	E	E1	L	L1	P
2F38002	R38 NSF	4	1/8	13	15	9.5	22.5	21	6
2F38008	R38 NSF	6	1/8	13	15	12.5	24.5	21	6
2F38009	R38 NSF	6	1/4	16	18	12.5	26	25	8
2F38010	R38 NSF	8	1/8	13	15	14.5	27.5	22.5	6
2F38011	R38 NSF	8	1/4	16	18	14.5	27.5	25	8
2F38013	R38 NSF	10	1/4	16	18	17	31.5	27	8
2F38014	R38 NSF	10	3/8	19	22	17	31.5	30.5	9

### L- MACHO CONICO R39 NSF

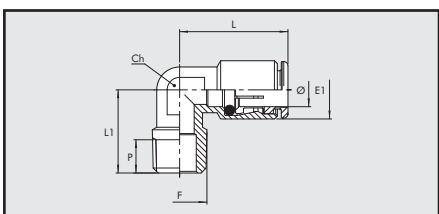

Cod.	Ref.	∅	F	Ch	E1	L	L1	P
2F39C02	R39 NSF	4	1/8	10	9.5	21	16	6.2
2F39C08	R39 NSF	6	1/8	10	11.8	23.5	16	6.2
2F39C09	R39 NSF	6	1/4	10	11.8	24	18.5	8.5
2F39C10	R39 NSF	8	1/8	12	14	26	17	6.2
2F39C11	R39 NSF	8	1/4	12	14	26	20	8.5
2F39C12	R39 NSF	8	3/8	14	14	27.5	22.5	9
2F39C13	R39 NSF	10	1/4	14	17	30.5	22	8.5